

10Gb/s XFP Optical Transceiver Module

SXP3103NV (-M, W)

(SR-1/I-64.1, 10GBASE-LR/LW, 1200-SM-LL-L, 1310nm DFB, PIN-PD)

Features

- ◆ 10Gb/s Serial Optical Interface
 - High quality and reliability optical device and sub-assemblies
 - 1310nm DFB laser for up to 10km operation over single mode fiber
 - High sensitivity PIN photo diode and TIA
- ◆ XFP MSA 4.5 Compliant
 - Easy supply management for hot pluggability
 - Duplex LC Receptacle
 - XFP Mechanical Interface with bail latch for easy removal (Bail color: Blue)
 - XFI High Speed Electrical Interface
 - 2-wire interface for management and diagnostic monitor
 - Tx_Disable and Rx_LOS functions
- ◆ Multi-Protocol
 - SONET OC-192/SDH STM-64/OUT-2
 - IEEE802.3ae 10Gigabit Ethernet/
10Gigabit Ethernet
 - 10G Fiber Channel
- ◆ Low Power Consumption
 - Single +3.3V Power supply
 - RoHS 6/6 Compliant



Applications

- ◆ SONET(OC-192)/SDH(STM64) line card
- ◆ 10GE Ethernet switches and routers
- ◆ 10GE Core routers
- ◆ 10GE Storage
- ◆ Inter Rack Connection
- ◆ Other high speed data connections

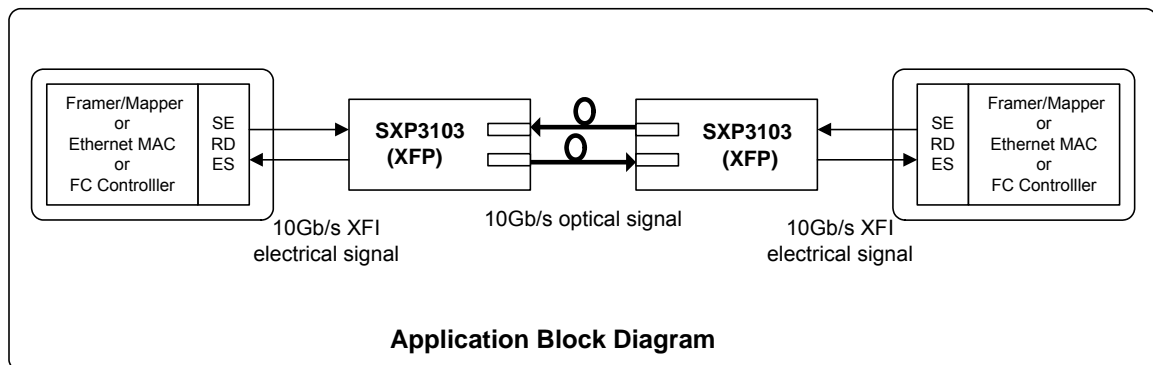

Application Block Diagram

1. General Description

The SXP3103NV is a very compact 10Gb/s optical transceiver module for serial optical communication applications at 10Gb/s. The SXP3103NV converts a 10Gb/s serial electrical data stream to 10Gb/s optical output signal and a 10Gb/s optical input signal to 10Gb/s serial electrical data streams. The high speed 10Gb/s electrical interface is fully compliant with XFI specification and allows FR4 host PCB trace up to 200mm.

The SXP3103NV is designed for use in a variety of 10Gb/s SONET/SDH equipment (9.95Gb/s) and Ethernet LAN (10.3Gb/s) and WAN (9.95Gb/s) and 10G Fibre channel(10.52G) applications. The high performance uncooled 1310nm DFB-LD transmitter and high sensitivity PIN receiver provide superior performance for SONET /SDH and Ethernet applications at up to 10km links.

The fully XFP compliant form factor provides hot pluggability, easy optical port upgrades and low EMI emission.

2. Functional Description

The SXP3103NV contains a duplex LC connector for the optical interface and a 30-pin connector for the electrical interface. Figure 2.1 shows the functional block diagram of SXP3103NV XFP Transceiver.

Transmitter Operation

The transceiver module receives 10Gb/s electrical data and transmits the data as an optical signal. The transmitter contains a Clock Data Recovery (CDR) circuit that reduces the jitter of received signal and reshapes the electrical signal before the electrical to optical (E-O) conversion. The optical output power is maintained constant by an automatic power control (APC) circuit. The transmitter output can be turned off by TX disable signal, at TX_DIS pin. When TX_DIS is asserted High, the transmitter is turned off.

Receiver Operation

The received optical signal is converted to serial electrical data signal. The optical receiver contains a CDR circuits that reshapes and retimes an electrical signal before sending out to the XFI channel (i.e. XFP connector and high speed signal traces).

The RX_LOS signal indicates insufficient optical power for reliable signal reception at the receiver.

Management Interface

A 2-wire interface (SCL, SDA) is used for serial ID, digital diagnostics and other control /monitor functions. The address of XFP transceiver is 1010000x. MOD_DESEL signal can be used in order to support multiple XFP modules on the same 2-wire interface bus.

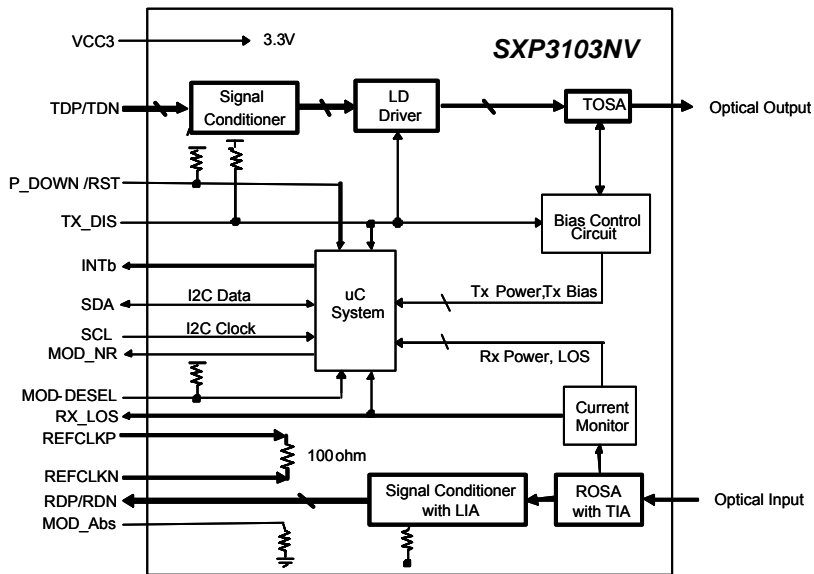
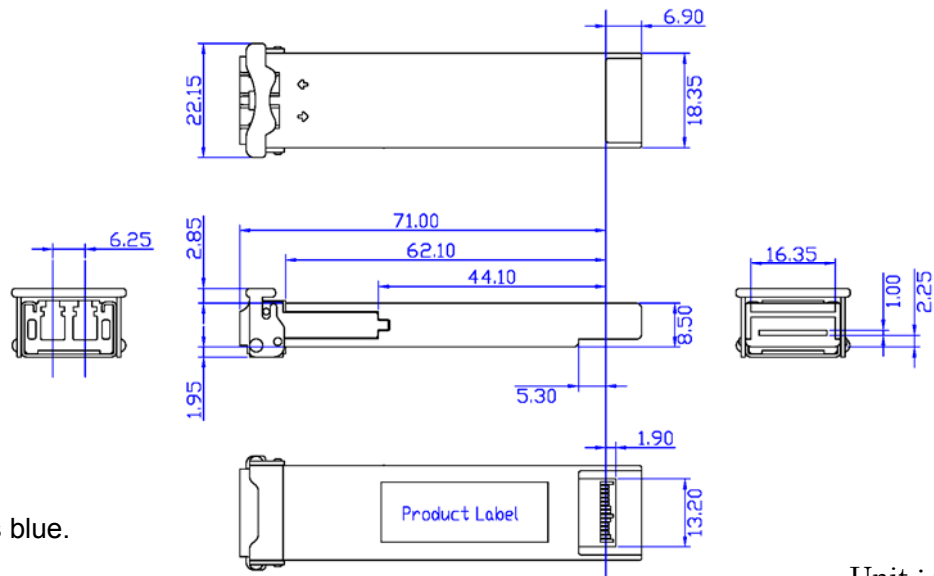

Figure 2.1. Functional Block Diagram

3. Package Dimensions

Figure 3.1 shows the package dimensions of SXP3103NV. SXP3103NV is designed to be compliant with XFP MSA specification. Package dimensions are specified in section 6.3 of the XFP MSA specification Rev. 4.5.



Unit : mm

Figure 3.1. Package dimensions

4. Pin Assignment and Pin Description

4.1. XFP Transceiver Electrical Pad Layout

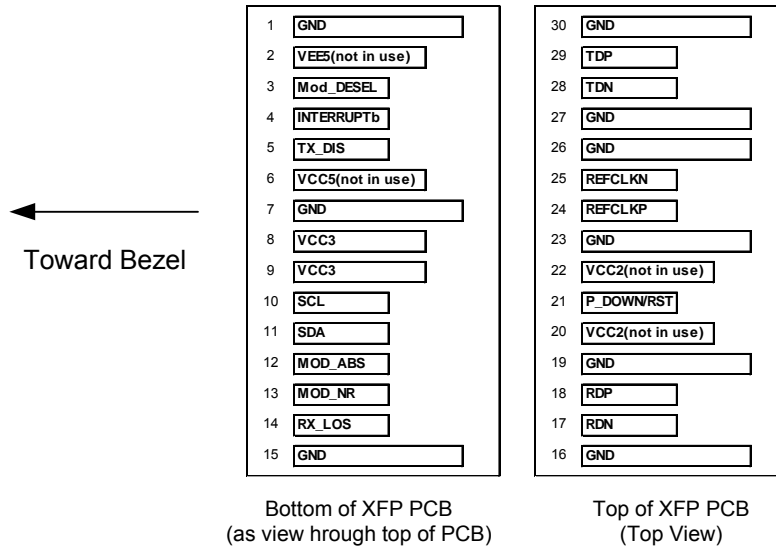

Figure 4.1. XFP Transceiver Electrical Pad Layout

4.2. Host PCB XFP Pinout

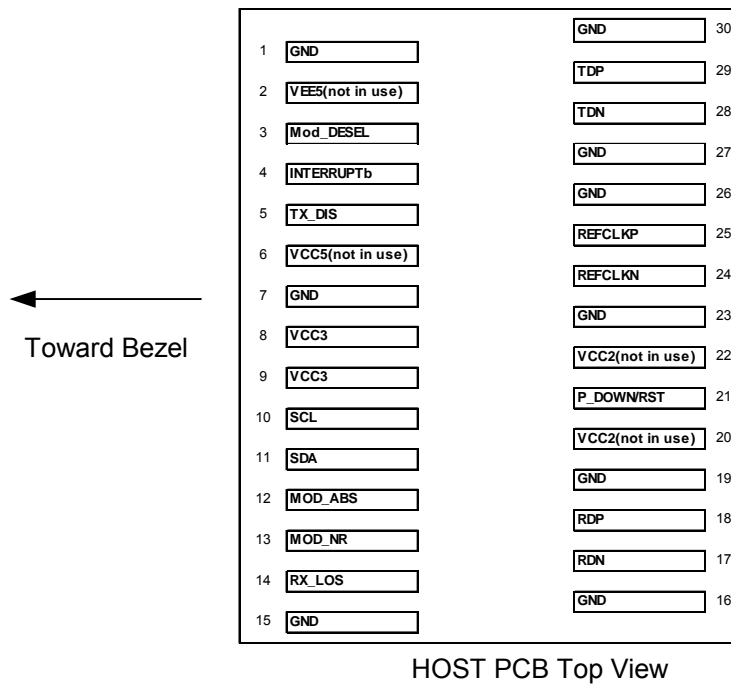

Figure 4.2. Host PCB XFP Pinout

4.3. Pin Descriptions

Table 4.3. Pin Description

Pin#	Name	Logic	Description	Note
1	GND		Module Ground	1
2	VEE5		-5.2V Power Supply , not in use	3
3	MOD_DESEL	LVTTL-I	Module De-select; When held Low allows module to respond to 2-wire serial interface	
4	INTERRUPTb	LVTTL-O	Indicates presence of an important condition, which can be read over the 2-wire serial interface. This pin is an open collector output and must be pulled up to host_Vcc on the host board.	2
5	TX_DIS	LVTTL-I	Transmitter Disable; When asserted High, transmitter output is turned off. This pin is pulled up to VCC3 in the module	
6	VCC5		+5V Power Supply, not in use	3
7	GND		Module Ground	1
8	VCC3		+3.3V Power Supply	
9	VCC3		+3.3V Power Supply	
10	SCL	I/O	2-wire serial interface clock. Host shall use a pull-up resistor connected to host_Vcc of +3.3V.	2
11	SDA	I/O	2-wire serial interface data. Host shall use a pull-up resistor connected to host_Vcc of +3.3V.	2
12	MOD_ABS	LVTTL-O	Indicates Module is not present. Host shall pull up this pin, and grounded in the module. "High" when the XFP module is absent from a host board.	2
13	MOD_NR	LVTTL-O	Module not ready; When High, Indicates Module Operational Fault. This pin is an open collector and must be pulled to host_Vcc on the host board.	2,4,5
14	RX_LOS	LVTTL-O	Receiver Loss of Signal; When high, indicates insufficient optical input power to the module. This pin is an open collector and must be pulled to host_Vcc on the host board.	2
15	GND		Module Ground	

Pin#	Name	Logic	Description	Note
16	GND		Module Ground	
17	RDN	CML-O	Receiver Inverted Data Output; AC coupled inside the module.	
18	RDP	CML-O	Receiver Non-Inverted Data Output; AC coupled in side the module.	
19	GND		Module Ground	1
20	VCC2		+1.8V Power Supply; not in use	3
21	P_DOWN/RST	LVTTTL-I	Power down; When High, module is limited power mode. Low for normal operation. Reset; The falling edge indicates complete reset of the module. This pin is pulled up to VCC3 in the module.	
22	VCC2		+1.8V Power Supply; not in use	3
23	GND		Module Ground	1
24	REFCLKP	PECL-I	Reference clock Non-Inverted Input; not in use	
25	REFCLKN	PECL-I	Reference clock Inverted Input; not in use	
26	GND		Module Ground	1
27	GND		Module Ground	1
28	TDN	CML-I	Transmitter Inverted Data Input; AC coupled in side the module.	
29	TDP	CML-I	Transmitter Non-Inverted Data Input; AC coupled in side the module.	
30	GND		Module Ground	1

Note

- 1: Module ground pins are isolated from the module case and chassis ground within the module.
- 2: Shall be pulled up with 4.7k to 10k ohm to a voltage between 3.15V and 3.45V on the host board.
- 3: Not connected internally.
- 4: Response time: typ. 20msec (XFP MSA Rev. 4.5 \leq 1msec)
- 5: MOD_NR = (TX LOL) or (RX LOL) or Tx-Fault.

5. Absolute Maximum Ratings and Recommended Operating Conditions

Table 5.1. Absolute Maximum Ratings

Parameter	Symbol	Min	Max	Unit	Note
Storage Temperature	Tst	-40	85	degC	
Relative Humidity (non-condensation)	RH		85	%	
Operating Case Temperature	Topc	-40	85	degC	1
Supply Voltage	VCC3	-0.5	3.6	V	
Voltage on LVTTL Input	Vilvttl	-0.5	VCC3+0.5	V	
LVTTL Output Current	Iolvttl		15	mA	
Voltage on Open Collector Output	Voco	0	6	V	
Receiver Input Optical Power(Average)	Mip		3	dBm	2

Note

- 1: Ta: -45 to 75degC with 1.5m/s airflow with an additional heat sink. (Reference conditions)
- 2: PIN Receiver

Table 5.2. Recommended Operating Conditions and Supply Requirements

Parameter	Symbol	Min	Max	Unit	Note
Operating Case Temperature	Topc	-5	70	degC	2
		-5	85		3
		-40	85		4
Relative Humidity (non-condensing)	Rhop		85	%	
Power Supply Voltage	VCC3	3.135	3.465	V	
Power Supply Current	ICC3		750	mA	1
Total Power Consumption	Pd	-	1.7	W	2
		-	2.0		3, 4

Note

- 1: The inrush current is included.
- 2: SXP3103NV
- 3: SXP3103NV-M
- 4: SXP3103NV-W

6. Electrical Interface

6.1. High Speed Electrical Interface

XFI Application Reference model

Figure 6.1.1 shows the high speed electrical interface (XFI) compliance points.

XFI electrical interface is specified for each compliance point in the chapter 3 of the XFP MSA specification.

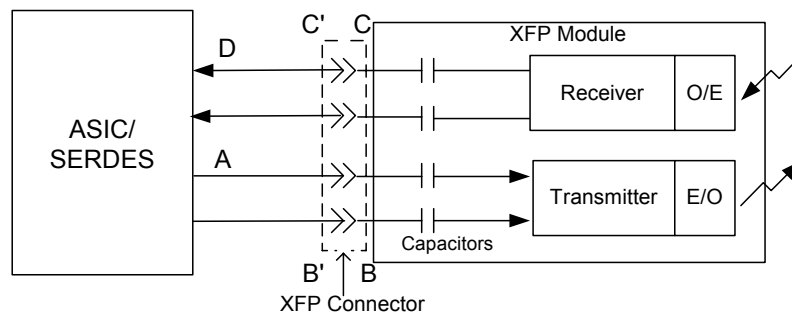

Figure 6.1.1. XFI Application Reference Model

XFI Module Transmitter Input Electrical Interface Specification at B'

Table 6.1.1. XFI Transmitter Input Electrical Specification at B'

Parameter -B'	symbol	Min	Typ	Max	Units	Note
Reference differential Input Impedance	Zd	-	100	-	Ohm	
Termination Mismatch	ΔZ_m	-		5	%	
Input AC Common mode Voltage		-		25	mV(RMS)	
Differential Input Return Loss	SDD11	20		-	dB	1
		8		-	dB	2
		See3		-		3
Comon Mode Input Return Loss	SCC11	3		-	dB	4
Differential to Common Mode Conversion	SCD11	10		-	dB	4
Total Input Non-DDJ Jitter	TJtnd	-		0.41	Ulp-p	
Total Input Jitter	TJ	-		0.61	Ulp-p	
Input Jitter for ITU-T 20kHz-80MHz	Gjin1	-		150	mUlp-p	
Input Jitter for ITU-T 4MHz-80MHz	Gjin2	-		50	mUlp-p	
Eye Mask	X1	-		0.305	UI	5
	Y1	60		-	mV	
	Y2	-		410	mV	

Note

1: 0.05 to 0.1 GHz

2: 0.1 to 5.5GHz

3: 5.5 to 12GHz, $SDD11(dB)=8-20.66\log_{10}(f/5.5)$, with f in GHz

4: 0.1 to 15GHz

5: Eye Mask is defined in Figure 6.1.2

XFI Module Receiver Output Electrical Interface Specification at C'

Table 6.1.2. XFI Receiver Output Electrical Specification at C'

Parameter -C'	symbol	Min	Typ	Max	Units	Note
Reference differential Output Impedance	Zd	-	100	-	Ohm	
Termination Mismatch	ΔZ_m	-		5	%	
Output AC Common mode Voltage		-		15	mV(RMS)	
Output Rise and Fall time (20%-80%)	trh, tfh	24		-	ps	
Differential Output Return Loss	SDD22	20		-	dB	1
		8		-	dB	2
		See3		-		3
Comon Mode Input Return Loss	SCC22	3		-	dB	4
Deterministic Jitter	TJtnd	-		0.18	Ulp-p	
Total Jitter	TJ	-		0.34	Ulp-p	
Eye Mask	X1	-		0.17	UI	5
	X2	-		0.42	UI	
	Y1	170		-	mV	
	Y2	-		425	mV	

Note

- 1: 0.05 to 0.1 GHz
- 2: 0.1 to 5.5GHz
- 3: 5.5 to 12GHz, $SDD11(dB)=8-20.66\text{Log}_{10}(f/5.5)$, with f in GHz
- 4: 0.1 to 15GHz
- 5: Eye Mask is defined in Figure 6.1.3

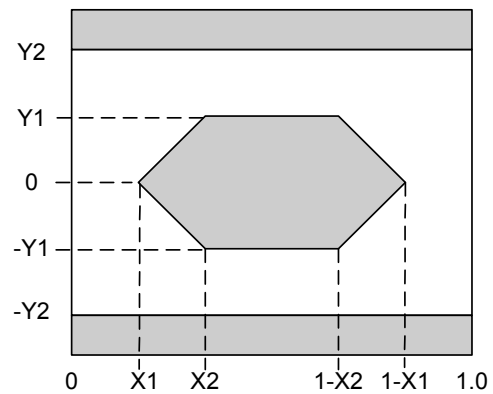
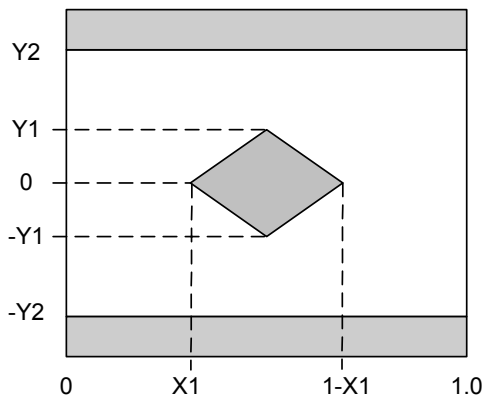

Figure 6.1.2. Transmitter Input Eye Mask Figure 6.1.3. Receiver Output Eye Mask

XFI Reference Clock

Note that the reference clock is not needed for SXP3103NV. The differential reference clock signals if used are internally terminated across 100ohm resistance as shown in Figure 2.1.

6.2. CDR Specification

Transmitter CDR

Table 6.2.1. Transmitter CDR Specification

Parameter	symbol	Min	Typ	Max	Units	Note
Jitter Transfer Bandwidth	BW	-		8	MHz	1
Jitter Transfer Peaking	Jp1	-		0.1	dB	2
	Jp2	-		1	dB	3

Note

- 1: In order to meet SONET/SDH jitter transfer requirement, de-jitter PLL will be needed on the host board SerDes.
- 2: Frequency < 120kHz
- 3: Frequency ≥ 120kHz

Receiver CDR

Table 6.2.2. Receiver CDR Specification

Parameter	symbol	Min	Typ	Max	Units	Note
Jitter Transfer Bandwidth	BW	-		12	MHz	
Jitter Transfer Peaking	Jp1	-		0.1	dB	1
	Jp2	-		1	dB	2

Note

- 1: Frequency < 120kHz
- 2: Frequency ≥ 120kHz

6.3. Low speed Electrical Interface

Table 6.3.1. Low Speed Control and Alarm Signals Electrical Interface

Parameter	symbol	Min	Typ	Max	Units	Note
XFP Interrupt, Mod_NR, RX_LOS	V _{ol}	0.0		0.4	V	1
	V _{oh}	V _{cc} -0.5		V _{cc} +0.3		2
XFP TX_DIS, P_DOWN/RST	V _{il}	-0.3		0.8	V	3
	V _{ih}	2.0		V _{CC3} +0.3		4
XFP SCL and SDA Output	V _{ol}	0.0		0.4	V	1
	V _{oh}	V _{cc} -0.5		V _{cc} +0.3		2
XFP SCL and SDA Input	V _{il}	-0.3		V _{CC3} *0.3	V	5
	V _{ih}	V _{CC3} *0.7		V _{CC3} +0.5		6
Capacitance for XFP SCL and SDA I/O pin	C _i	-		14	pF	
Total bus capacitive load for SCL and SDA	C _b	-		100	pF	7
		-		400	pF	8

Note

- 1: Pull-up resistor must be connected to host_Vcc on the host board. I_{ol}(max)=3mA
- 2: Pull-up resistor must be connected to host_Vcc on the host board.
- 3: Pull-up resistor connected to VCC3 within XFP module. I_{il}(max)= -10μA.
- 4: Pull-up resistor connected to VCC3 within XFP module. I_{ih}(max)= 10μA.
- 5: Pull-up resistor must be connected to host_Vcc on the host board. I_{ol}(max)= -10μA.
- 6: Pull-up resistor must be connected to host_Vcc on the host board. I_{ol}(max)= 10μA.
- 7: at 400KHz, 3.0kohms, at 100kHz 8.0kohms max
- 8: at 400KHz, 0.8kohms, at 100kHz 2.0kohms max

7. Optical Interface

Table 7.1. Optical Interface Note:

Transmitter Optical Interface						
Parameter	Symbol	Min	Typical	Max	Unit	Note
Operating Data Rate	-	9.95		10.52	Gb/s	1
Output Center Wavelength	l _{tc}	1290	1310	1330	nm	3
Spectral Width	d _l	-		1	nm	
SMSR	SMSR	30		-	dB	
Average Output Power	P _o	-6		-1.0	dBm	
Disabled Power	P _{off}	-		-30	dBm	
Extinction Ratio	ER ₁	6		-	dB	
Minimum OMA (10G Ethernet)	OMA	-5.2		-	dBm	
Minimum OMA-TDP (10G Ethernet)	OMAt _{dp}	-6.2		-	dBm	
Eye Mask 1 (SONET/SDH)		GR-253-CORE/ITU-T G.691				
Eye Mask 2 (10G Ethernet)		IEEE802.3ae				3
Generation Jitter 1 (20kHz - 80MHz)		-		0.15	Ulp-p	2,4
Generation Jitter 2 (4MHz - 80MHz)		-		0.1	Ulp-p	2,4
RIN	RIN	-		-128	dB/Hz	
Optical Path						
Parameter	Symbol	Min	Typical	Max	Unit	Note
Chromatic Dispersion (SONET/SDH)	CD	-		6.6	ps/nm	
Operating Distance (10G Ethernet)		-		10	km	
Attenuation (SONET/SDH)		0		4	dB	
Channel Insertion Loss (10G Ethernet)		0		6	dB	
Maximum DGD (SONET/SDH)	DGD	-		30	ps	
Receiver Optical Interface						
Parameter	Symbol	Min	Typical	Max	Unit	Note
Operating Data Rate	-	9.95		10.52	Gb/s	1
Input Center Wavelength	l _{rc}	1260		1565	nm	3
Overload	R _{ovl}	0.5		-	dBm	
Minimum Sensitivity	P _{min}	-		-11	dBm	
Sensitivity in OMA	OMA ₀	-		-12.6	dBm	
Stressed Sensitivity in OMA	OMA _{st}	-		-10.3	dBm	
RX_LOS Assert Level	RLOS _a	-30		-25	dBm	
RX_LOS Deassert Level	RLOS _d	-		-22	dBm	
RX_LOS Hysteresis	RLOS _h	1		5	dB	
Optical Path Penalty	PN	-		1	dB	
Optical Return Loss	ORL	14		-	dB	
Jitter Tolerance	JTL	GR-253-CORE/ITU-T G.783				

- 1: Data rate tolerance
SR-1/I-64.1,10GBASE-LW:typ.+/-20ppm
10GBASE-LR: typ.+/-100ppm
- 2: Measured at 9.95328Gbps, Framed PRBS2³¹-1, NRZ
- 3: Measured at 10.51875Gbps, Non-framed PRBS2³¹-1
- 4: Measured by using Sumitomo evaluation board.

8. Electrical and Optical I/O Signal Relationship

Table.8.1. TX_DIS vs. Optical Output Power

TX_DIS	Optical Output Power
Low ($V_{IL} = -0.3$ to $0.8V$)	Enabled
High ($V_{IH} = 2.0$ to $VCC3+0.3V$)	Disabled ($< -30dBm$)

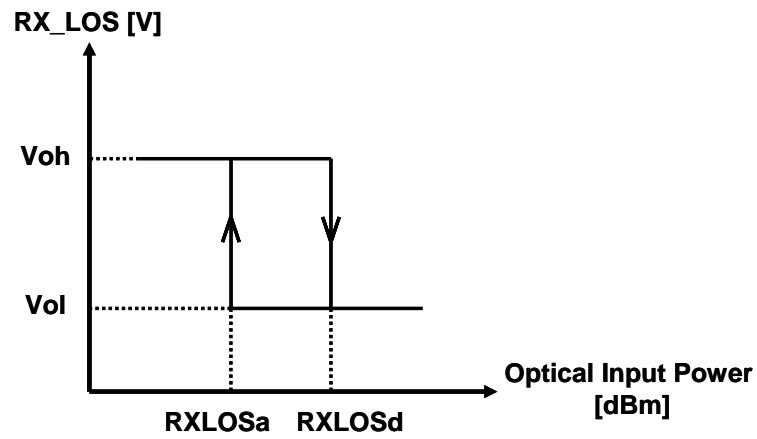

Figure.8.1. Optical Input Power vs. RX_LOS

9. User Interface

9.1. XFP Mechanical Interface

XFP Mechanical Interface is specified in the Chapter 6 in the XFP MSA specification.

XFP Mechanical Components

Figure 9.1 shows the XFP transceiver concept and mechanical components.

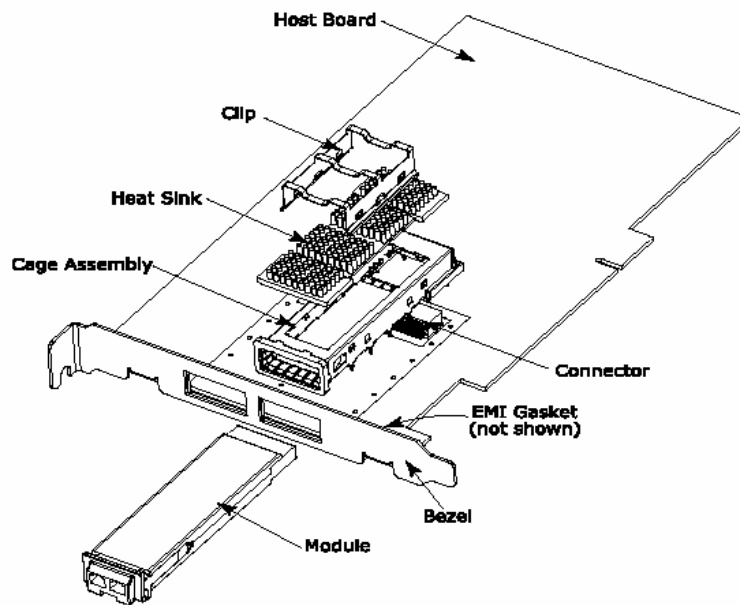

Figure 9.1. XFP Mechanical Interface Concept and Components

XFP Host board Mechanical Layout

XFP Host Board Layout is specified in the Figure 35 of the XFP MSA specification (Rev. 4.5).

Host Board XFP Connector Footprint and Layout

Host board XFP connector layout is specified in the Figure 36 of the XFP MSA Specification (Rev. 4.5).

XFP Datum Alignment and Bezel Design

XFP datum alignment (depth) is specified in the Figure 30 of the XFP MSA specification (Rev. 4.5).

The recommended bezel design is specified in the Figure 37 of the XFP MSA specification (Rev. 4.5).

XFP Connector and XFP Cage Assembly

The XFP 30-contact connector mechanical specification is shown in Figure 39 of the XFP MSA specification (Rev. 4.5).

The XFP Cage Assembly mechanical specification is shown in the Figure 41 of the XFP MSA specification (Rev. 4.5).

9.2. Management Interface

XFP 2-Wire Serial Interface Protocol

XFP 2-wire serial interface is specified in the Chapter 4 of the XFP MSA specification.

The XFP 2-wire serial interface is used for serial ID, digital diagnostics, and certain control functions. The 2-wire serial interface is mandatory for all XFP modules.

The 2-wire serial interface address of the XFP module is 1010000X(A0h). In order to access to multiple modules on the same 2-wire serial bus, the XFP has a MOD_DESEL (module deselect pin). This pin (which is pull high or deselected in the module) must be held low by the host to select of interest and allow communication over 2-wire serial interface. The module must not respond to or accept 2-wire serial bus instructions unless it is selected.

XFP Management Interface

XFP Managed interface is specified in the Chapter 5 of the XFP MSA specification.

The Figure 9.2 shows the structure of the memory map. The normal 256 Byte address space is divided into lower and upper blocks of 128 Bytes. The lower block of 128 Byte is always directly available and is used for the diagnostics and control functions that must be accessed repeatedly. Multiple blocks of memories are available in the upper 128 Bytes of the address space. These are individually addressed through a table select Byte which the user enters into a location in the lower address space. The upper address space tables are used for less frequently accessed functions and control space for future standards definition.

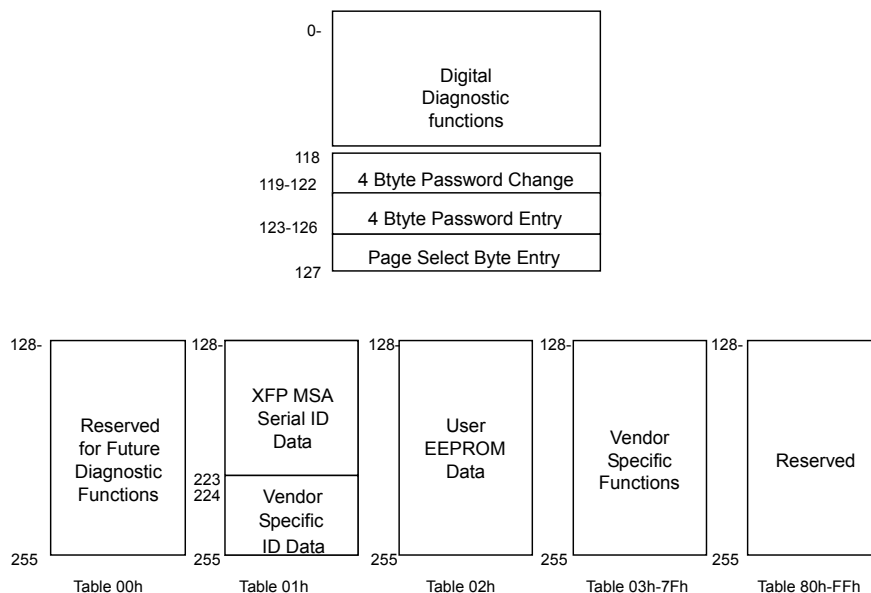

Figure 9.2. 2-wire Serial Interface Memory Map

9.3. A/D Accuracy and Values

Table 9.3.1. A/D Accuracy

Data Address	Parameter	Accuracy	Relative accuracy	Units Display	Note
96-97	Temperature	+/-3degC	NA	Signed 2's complement integer degC	Junction temperature of monitoring IC.
98-99	Reserved				
100-101	Tx Bias	+/-10%	NA	×2μA	Specified by nominal value
102-103	Tx Power	+/-2dB (Note1) (-6 to +0.5dBm)	+/-1dB (Note2)	×0.1μW	Average Power
104-105	Rx Power	+/-2dB (Note1) (-15 to +0.5dBm)	+/-1dB (Note2)	×0.1μW	At specified transmitter wavelength.
106-107	Vcc3	+/-3%	NA	×100μV	3.3V Only

Table 9.3.2. A/D Values

Byte	Bit	Name	Description
96	All	Temperature MSB	Signed 2's complement integer temperature (-40 to +125degC) based on internal temperature measurement
97	All	Temperature LSB	Fractional part of temperature(count/256)
98-99	All		Reserved
100	All	Tx Bias MSB	Measured Laser Bias Current in mA. Bias current is full 16 bit value *2uA. (Full range of 0 to 131mA)
101	All	Tx Bias LSB	
102	All	Tx Power MSB	Measured Tx output power in mW. Tx power is full 16 bit value *0.1uW. (Full range of -40 to +8.2dBm)
103	All	Tx Power LSB	
104	All	Rx Power MSB	Measured Rx input power in mW. Tx power is full 16 bit value *0.1uW. (Full range of -40 to +8.2dBm)
105	All	Rx Power LSB	
106	All	Vcc3 MSB	Internally measured transceiver supply voltage. Vcc is full 16 bit value*100uV. (Full range of 0 to +6.55 Volts)
107	All	Vcc3 LSB	
108	All	AUX 2 MSB	Reserved
109	All	AUX 2 LSB	

Note

- 1: Over specified temperature and voltage
- 2: Over specified temperature and voltage range over the life of the product into a fixed measurement system



9.4. Serial ID Memory Map (Data Field – Table 01h)

Table 9.4.1. SXP3103NV EEPROM Data (Table 01h)

Address	Size (Bytes)	Name	Hex	ASC	Description
Base ID Filed					
128	1	Identifier	06		XFP module
129	1	Ext. Identifier	50		2.5W Max With CDR
130	1	Connector	07		LC Connector
131	8	Tranciver	44		10GBASE-LR/LW
132			40		1200-SM-LL-L
133			00		
134			00		
135			40		I-64.1
136			00		
137			00		
138			00		
139	1	Encoding	B0		64B/66B, SONET Scrambled, NRZ
140	1	BR-Min	64		9.95Gbps
141	1	BR-Max	69		10.5Gbps
142	1	Length (SMF)-km	0A		10km
143	1	Length (E-50 μm)	00		
144	1	Length (50 μm)	00		
145	1	Length (62.5 μm)	00		
146	1	Length (Copper)	00		
147	1	Device Tech	40		1310nm DFB, PIN etector
148	16	Vendor name	53	S	
149			75	u	
150			6D	m	
151			69	i	
152			74	t	
153			6F	o	
154			6D	m	
155			6F	o	
156			45	E	
157			6C	l	
158			65	e	
159			63	c	
160			74	t	
161			72	r	
162			69	i	
163			63	c	
164	1	CDR Support	F8		CDR support for 9.95Gbps CDR support for 10.3Gbps CDR support for 10.5Gbps CDR support for 10.7Gbps CDR support for 11.1Gbps
165	3	Vendor OUI	00		
166			00		
167			5F		
168	16	Vendor PN	53	S	
169			58	X	
170			50	P	
171			33	3	
172			31	1	
173			30	0	
174			33	3	
175			4E	N	
176			56	V	
177			20		
178			20		
179			20		
180			20		
181			20		
182			20		
183			20		
184	2	Vendor rev	41 to 5A	A to Z	Variable
185			20		
186	2	Wavelength	66		1310nm @ RT
187			58		
188	2	Wavelength Tolerance	0F		+/-20nm (Note1)
189			A0		
190	1	Max Case Temp	46		70degC
191	1	CC BASE	Note2		

Address	Size (Bytes)	Name	Hex	ASC	Description
Extended ID Field					
192	4	Power Supply	55		1.7W
193			78		1.2W (Note3)
194			08		800mA (Note4)
195			00		(Note5)
196					
197	16	Vendor SN		Note6	
198					
199					
200					
201					
202					
203					
204					
205					
206					
207					
208					
209					
210					
211					
212			8	Date Code	
213					
214					
215					
216					
217					
218					
219					
220	1	Diagnostic Monitoring Type	08		No BER Support Average Power
221	1	Enhanced Options	60		Optional Soft TX Disable Optional Soft P down
222	1	Aux Monitoring	70		+3.3V Support Voltage Auxiliary monitoring not implemented
223	1	CC_EXT	Note8		
Vendor Specific ID Fileds					
224	32	Vendor Specific	FF		
225			FF		
226			FF		
227			FF		
228			FF		
229			FF		
230			FF		
231			FF		
232			FF		
233			FF		
234			FF		
235			FF		
236			FF		
237			FF		
238			FF		
239			FF		
240			FF		
241			FF		
242			FF		
243			FF		
244			FF		
245			FF		
246			FF		
247			FF		
248			FF		
249			FF		
250			FF		
251			FF		
252			FF		
253			FF		
254			FF		
255			FF		

SXP3103NV-M EEPROM Data (Table 01h)

Address	Size (Bytes)	Name	Hex	ASC	Description
Base ID Filed					
128	1	Identifier	06		XFP module
129	1	Ext. Identifier	50		2.5W Max With CDR
130	1	Connector	07		LC Connector
131	8	Tranciver	44		10GBASE-LR/LW
132			40		1200-SM-LL-L
133			00		
134			00		
135			40		I-64.1
136			00		
137			00		
138			00		
139	1	Encoding	B0		64B/66B, SONET Scrambled, NRZ
140	1	BR-Min	64		9.95Gbps
141	1	BR-Max	69		10.5Gbps
142	1	Length (SMF)-km	0A		10km
143	1	Length (E-50 μm)	00		
144	1	Length (50 μm)	00		
145	1	Length (62.5 μm)	00		
146	1	Length (Copper)	00		
147	1	Device Tech	40		1310nm DFB, PIN etector
148	16	Vendor name	53	S	
149			75	u	
150			6D	m	
151			69	i	
152			74	t	
153			6F	o	
154			6D	m	
155			6F	o	
156			45	E	
157			6C	l	
158			65	e	
159			63	c	
160			74	t	
161			72	r	
162			69	i	
163			63	c	
164	1	CDR Support	F8		CDR support for 9.95Gbps CDR support for 10.3Gbps CDR support for 10.5Gbps CDR support for 10.7Gbps CDR support for 11.1Gbps
165	3	Vendor OUI	00		
166			00		
167			5F		
168	16	Vendor PN	53	S	
169			58	X	
170			50	P	
171			33	3	
172			31	1	
173			30	0	
174			33	3	
175			4E	N	
176			56	V	
177			2D	-	
178			4D	M	
179			20		
180			20		
181			20		
182			20		
183			20		
184	2	Vendor rev	41 to 5A	A to Z	Variable
185			20		
186	2	Wavelength	66		1310nm @ RT
187			58		
188	2	Wavelength Tolerance	0F		+/-20nm (Note1)
189			A0		
190	1	Max Case Temp	55		85degC
191	1	CC_BASE	Note2		
Extended ID Field					
192	4	Power Supply	64		2.0W
193			78		1.2W (Note3)
194			08		800mA (Note4)
195			00		(Note5)
196	16	Vendor SN			
197					
198					
199					
200					
201					
202					
203					
204					
205					
206					
207					
208					
209					
210					
211					
212	8	Date Code			
213					
214					
215					
216					
217					
218					
219					
220	1	Diagnostic Monitoring Type	08		No BER Support Average Power
221	1	Enhanced Options	60		Optional Soft TX Disable Optional Soft P down +3.3V Support Voltage
222	1	Aux Monitoring	70		Auxiliary monitoring not implemented
223	1	CC_EXT	Note8		
Vendor Specific ID Fileds					
224	32	Vendor Specific			FF
225					FF
226					FF
227					FF
228					FF
229					FF
230					FF
231					FF
232					FF
233					FF
234					FF
235					FF
236					FF
237					FF
238					FF
239					FF
240					FF
241					FF
242					FF
243					FF
244					FF
245					FF
246					FF
247					FF
248					FF
249					FF
250					FF
251					FF
252					FF
253					FF
254					FF

SXP3103NV-W EEPROM Data (Table 01h)

Address	Size (Bytes)	Name	Hex	ASC	Description
Base ID Filed					
128	1	Identifier	06		XFP module
129	1	Ext. Identifier	50		2.5W Max With CDR
130	1	Connector	07		LC Connector
131	8	Tranciver	44		10GBASE-LR/LW
132			40		1200-SM-LL-L
133			00		
134			00		
135			40		I-64.1
136			00		
137			00		
138			00		
139	1	Encoding	B0		64B/66B, SONET Scrambled, NRZ
140	1	BR-Min	64		9.95Gbps
141	1	BR-Max	69		10.5Gbps
142	1	Length (SMF)-km	0A		10km
143	1	Length (E-50 μm)	00		
144	1	Length (50 μm)	00		
145	1	Length (62.5 μm)	00		
146	1	Length (Copper)	00		
147	1	Device Tech	40		1310nm DFB, PIN etector
148	16	Vendor name	53	S	
149			75	u	
150			6D	m	
151			69	i	
152			74	t	
153			6F	o	
154			6D	m	
155			6F	o	
156			45	E	
157			6C	l	
158			65	e	
159			63	c	
160			74	t	
161			72	r	
162			69	i	
163			63	c	
164	1	CDR Support	F8		CDR support for 9.95Gbps CDR support for 10.3Gbps CDR support for 10.5Gbps CDR support for 10.7Gbps CDR support for 11.1Gbps
165	3	Vendor OUI	00		
166			00		
167			5F		
168	16	Vendor PN	53	S	
169			58	X	
170			50	P	
171			33	3	
172			31	1	
173			30	0	
174			33	3	
175			4E	N	
176			56	V	
177			2D	-	
178			57	W	
179			20		
180			20		
181			20		
182			20		
183			20		
184	2	Vendor rev	41 to 5A	A to Z	Variable
185			20		
186	2	Wavelength	66		1310nm @ RT
187			58		
188	2	Wavelength Tolerance	0F		+/-20nm (Note1)
189			A0		
190	1	Max Case Temp	55		85degC
191	1	CC_BASE	Note2		
Extended ID Field					
192	4	Power Supply	64		2.0W
193			78		1.2W (Note3)
194			08		800mA (Note4)
195			00		(Note5)
196					
197	16	Vendor SN			
198					
199					
200					
201					
202					
203					
204					
205					
206					
207					
208					
209					
210					
211					
212			8	Date Code	
213					
214					
215					
216					
217					
218					
219					
220	1	Diagnostic Monitoring Type	08		No BER Support Average Power
221	1	Enhanced Options	60		Optional Soft TX Disable Optional Soft P_down
222	1	Aux Monitoring	70		+3.3V Support Voltage Auxiliary monitoring not implemented
223	1	CC_EXT	Note8		
Vendor Specific ID Fileds					
224	32	Vendor Specific	FF		
225			FF		
226			FF		
227			FF		
228			FF		
229			FF		
230			FF		
231			FF		
232			FF		
233			FF		
234			FF		
235			FF		
236			FF		
237			FF		
238			FF		
239			FF		
240			FF		
241			FF		
242			FF		
243			FF		
244			FF		
245			FF		
246			FF		
247			FF		
248			FF		
249			FF		
250			FF		
251			FF		
252			FF		
253			FF		
254			FF		

Note1. The guaranteed +/- range of transmitter output wavelength under all normal operating conditions.

Note2. Address 191 is check sum of bytes 128 to 190.

Note3. Maximum total power dissipation in power down mode

Note4. +5V is not in use. Note5. +1.8V/-5.2V is not in use.

Note6. Address 196 to 211 Vendor Serial Number

Note7. Address 212 to 219 Date code

Note8. Address 223 is check sum of bytes 192 to 222.

9.5. Alarm and warning threshold (Lower Table memory map)

Table 9.5.1. SXP3103NV EEPROM Data (Lower Table memory map)

Address	Name of field	Hex	Value	Hex	Value	Hex	Value	Unit
		SXP3103NV		SXP3103NV-M		SXP3103NV-W		
2	Temp High Alarm	50	80	5F	95	5F	95	degC
3		0		0		0		
4	Temp Low Alarm	F1	-15	F1	-15	CE	-50	degC
5		0		0		0		
6	Temp High Warning	4B	75	5A	90	5A	90	degC
7		0		0		0		
8	Temp Low Warning	F6	-10	F6	-10	D3	-45	degC
9		0		0		0		
18	Bias High Alarm	C3	100	C3	100	C3	100	mA
19		50		50		50		
20	Bias Low Alarm	00	0	00	0	00	0	mA
21		00		00		00		
22	Bias High Warning	9C	80	9C	80	9C	80	mA
23		40		40		40		
24	Bias Low Warning	00	0	00	0	00	0	mA
25		00		00		00		
26	TX Power High Alarm	3D	2	3D	2	3D	2	dBm
27		E8		E8		E8		
28	TX Power Low Alarm	04	-9	04	-9	04	-9	dBm
29		EA		EA		EA		
30	TX Power High Warning	27	0	27	0	27	0	dBm
31		10		10		10		
32	TX Power Low Warning	07	-7	07	-7	07	-7	dBm
33		CB		CB		CB		
34	RX Power High Alarm	45	2.5	45	2.5	45	2.5	dBm
35		76		76		76		
36	RX Power Low Alarm	00	-100	00	-100	00	-100	dBm
37		00		00		00		
38	RX Power High Warning	37	1.5	37	1.5	37	1.5	dBm
39		2D		2D		2D		
40	RX Power Low Warning	01	-15.5	01	-15.5	01	-15.5	dBm
41		19		19		19		
42	Aux 1 High Alarm	8D	36300	8D	36300	8D	36300	100uV
43		CC		CC		CC		
44	Aux 1 Low Alarm	74	29700	74	29700	74	29700	100uV
45		04		04		04		
46	Aux 1 High Warning	87	34650	87	34650	87	34650	100uV
47		5A		5A		5A		
48	Aux 1 Low Warning	7A	31350	7A	31350	7A	31350	100uV
49		76		76		76		
50	Aux 2 High Alarm	00	0	00	0	00	0	Not in use
51		00		00		00		
52	Aux 2 Low Alarm	00	0	00	0	00	0	Not in use
53		00		00		00		
54	Aux 2 High Warning	00	0	00	0	00	0	Not in use
55		00		00		00		
56	Aux 2 Low Warning	00	0	00	0	00	0	Not in use
57		00		00		00		

9.6. Supply filter

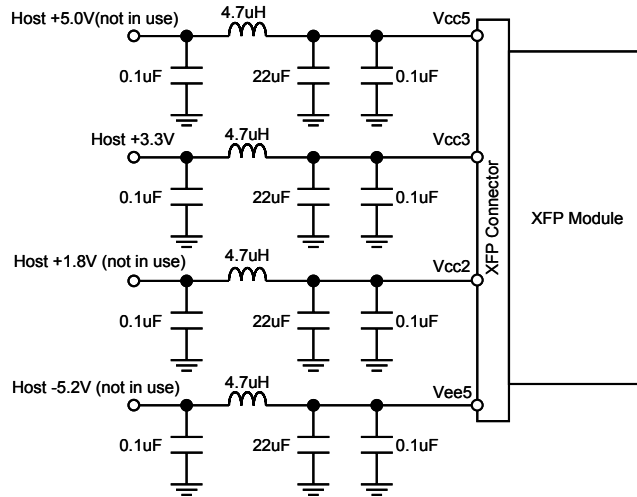

Figure 9.6. Supply Filter

9.7. Recommended Electrical Interface

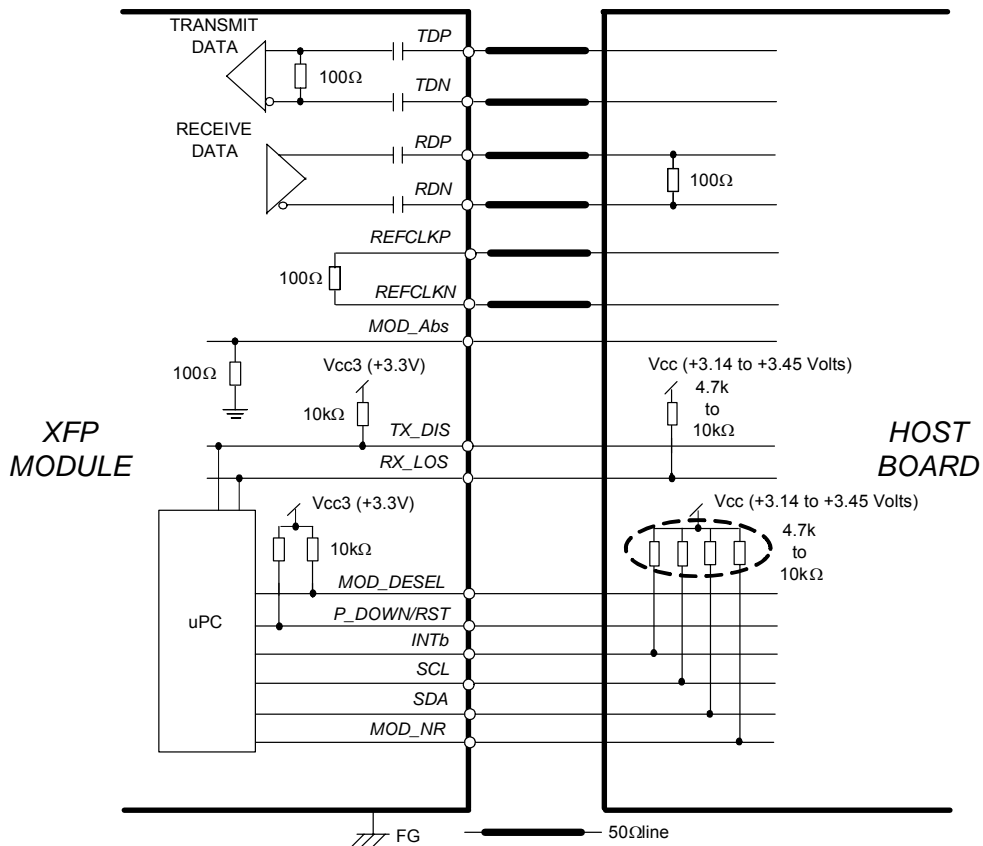

Figure 9.7. Recommended Electrical Interface

10. Qualification Testing

The SXP3103NV is qualified to Sumitomo Electric Industries internal design and manufacturing standards. Telecordia GR-468-CORE reliability test standards, using methods per MIL-STD-883 for mechanical integrity, endurance, moisture, flammability and ESD thresholds, are followed.

11. Laser Safety Information

The SXP3103NV uses a semiconductor laser system that is classified as Class 1 laser products per the Laser Safety requirements of FDA/CDRH, 21 CFR1040.10 and 1040.11. These products have also been tested and certified as Class 1 laser products per IEC 60825-1:2007 and IEC60825-1:2001 International standards.

Caution

If this product is used under conditions not recommended in the specification or is used with unauthorized revision, the classification for laser product safety is invalid. Reclassify the product at your responsibility and take appropriate safety measures.

12. Electromagnetic Compatibility (Pending)

EMI (Emission)

The SXP3103NV is designed to meet FCC Class B limits for emissions and noise immunity per CENELEC EN50 081 and 082 specifications.

RF Immunity

The SXP3103NV has an immunity to operate when tested in accordance with IEC 61000-4-3 (80- 1000MHz, Test Level 3) and GR-1089.

Electrostatic Discharge (ESD) Immunity

The SXP3103NV has an immunity against direct and indirect ESD when tested accordance with IEC 61000-4-2.

13. RoHS COMPLIANCE

Compliance versus requirements contained inside the following reference document is guaranteed: "Directive 2002/95/EC of 27 January 2003 on the restriction of the use of certain hazardous substances in electrical and electronic equipment from official journal of European Union (European Parliament and of the Council). This product is Compliant at RoHS-6/6 level and contains no leaded solders.

14. Ordering Information

14.1. Part Numbering System

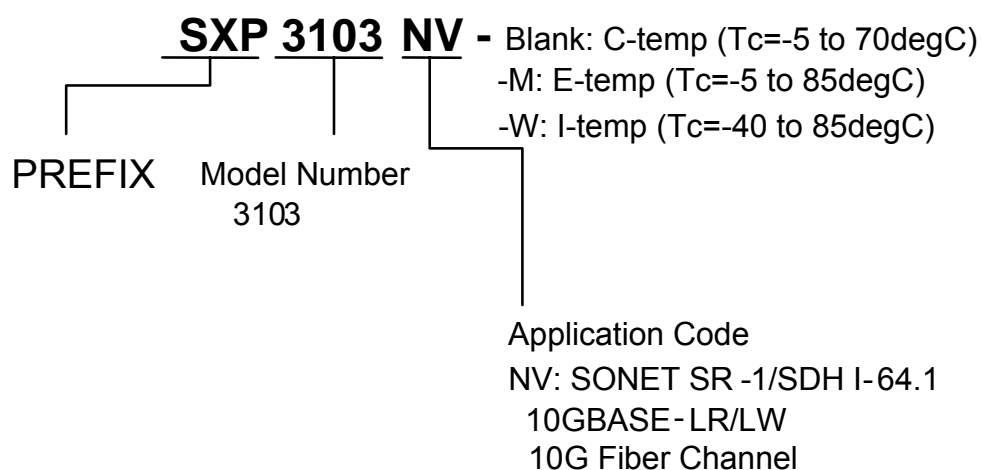

14.2. Evaluation Board Kit

For test purposes, Evaluation Board model number SK3101A and SP3101A may be ordered to use with the SXP3101 Series transceivers.

- SK3101A : SPX3101 XFP evaluation board
- SP3101A : XFP 2-wire serial interface evaluation kit

14.3. Ordering Number Code

Table 14. SXP3101 Application Code

P/N	Distance	Fiber	E/O	O/E	ITU-T G.691	Telecordi a	IEEE 802.3ae
SXP3103NV	10km	STD-SMF	1.31mm DEB	PIN	I-64.1	SR-1	10GBASE- LR

14.4. Firmware version

This product contains the firmware inside. Sumitomo Electric may upgrade the firmware version without advance notice as far as such would be upper compatible. When customer should prefer to have the current firmware version, Sumitomo Electric will accommodate such request and will assign customized part number for this purpose.

14.5. I2C Interface

If the serial clock(SCL) is more than 100kHz, the SCL is held in line low(clock stretching) during an I2C read or white operation.

15. Label Information

SXP3103NV



SXP3103NV-M



SXP3103NV-W



16. Contact Information

U.S.A.

Sumitomo Electric Device Innovations, U.S.A., Inc.

<West Coast (USA Headquarters)>

2355 Zanker Rd. San Jose, CA 95131-1138, USA

Tel: +1-408-232-9500

Fax: +1-408-428-9111

<East Coast>

4021 Stirrup Creek Drive, Suite 200, Durham, NC 27703, USA

Tel: +1-919-361-1600

Fax: +1-919-361-1619

Email: information@sei-device.com

<http://www.sei-device.com/>

Europe

Sumitomo Electric Europe Ltd.

220 Centennial Park, Elstree, Herts, WD6 3SL UK

Tel: +44-208-953-8681

Fax: +44-208-207-5950

E-mail: photonics@sumielectric.com

<http://www.sumielectric.com>

Asia

Sumitomo Electrics Asia Ltd.

Photonics Department

Room 2624 - 2637, 26F., Sun Hung Kai Center, 30 Harbour Road, Wanchai, Hongkong.

Tel: +852-2576-0080

Fax: +852-2576-6412

Japan

Sumitomo Electric Industries, Ltd.

Device Sales Department

<Tokyo>

3-9-1, Shibaura, Minato-ku, Tokyo 108-8539, Japan

TEL +81-3-6722-3286

FAX +81-3-6722-3284

<Osaka>

4-5-33, Kitahama, Chuo-ku, Osaka 541-0041, Japan

Tel: +81-6-6220-4245

Fax: +81-6-6222-6231

E-mail: optoele-sales-pro-sml@list.sei.jp

<http://www.sei.co.jp/products/index.html>